

# SKYMASTER SERIES APS 750

## THREE-AXIS POSITIONER, 750 kg CAPACITY



### Technical data

Max. load (N)	7500
Rotation speed (rpm)	0,09-2
Max. rotational torque (Nm)	600
Tilting torque (Nm)	1500
Tilting / angle (°)	hydr 135
Tilting time 0-max angle (s)	25
Table plate diameter (mm)	700
T-slots on table plate	3x M12 DIN508
Center hole dia (mm)	700
Max.welding current (A)	700
Height min-max (mm)	730-1450
Width (mm)	700
Length (mm)	1580
Weight (kg)	550
Mains supply connection 50 Hz	3x400V+N+PE
Power (A)	16

Due to continuous R&D, Pemamek Ltd reserves the right to change the specification without notice.



## PEMA SKYMASTER SERIES

PEMA Skymaster positioner for extra-heavy work. The height, tilt and rotating speed of work-piece are fully adjustable.

- Work-pieces can be set to the best possible welding positions. As a result welding productivity can be raised significantly.

- Hundreds of man-hours saved yearly compared to manual work-piece handling. With PEMA Skymaster these hours can be used on actual productive work.

- Always the optimal dimensions for your product on purposes. Standard selection from 250 kg up to 35,000 kg.

- Large movements - compact in size
- Precise hydraulic 3-axis movements
- Remote control for all functions
- Integration to other PEMA solutions
- Safety valves in hydraulic system
- Digital RPM-display
- Self-locking gears
- Extensive world-wide PEMA service
- Fast delivery and production start-up

### BETTER PRODUCTIVITY

Lift , rotate or tilt the workpiece. Skymaster guarantees optimal working position, always.

### IMPROVED QUALITY

Good ergonomics and safety secure welder's high motivation and working quality.

### DESIGNED TO LAST

Engineered to endure even the most robust conditions. Partner that will not let you down.



Optional accessories

- Foot pedal for start/stop of rotation
- Foot pedal for speed control of rotation
- External control of rotation
- Wireless remote control



Wired RC32H-remote included.

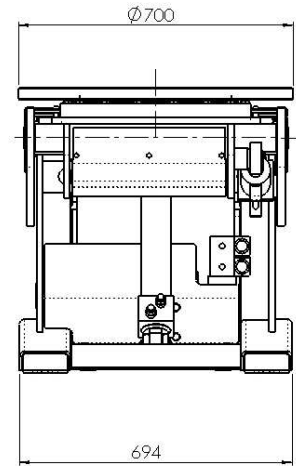
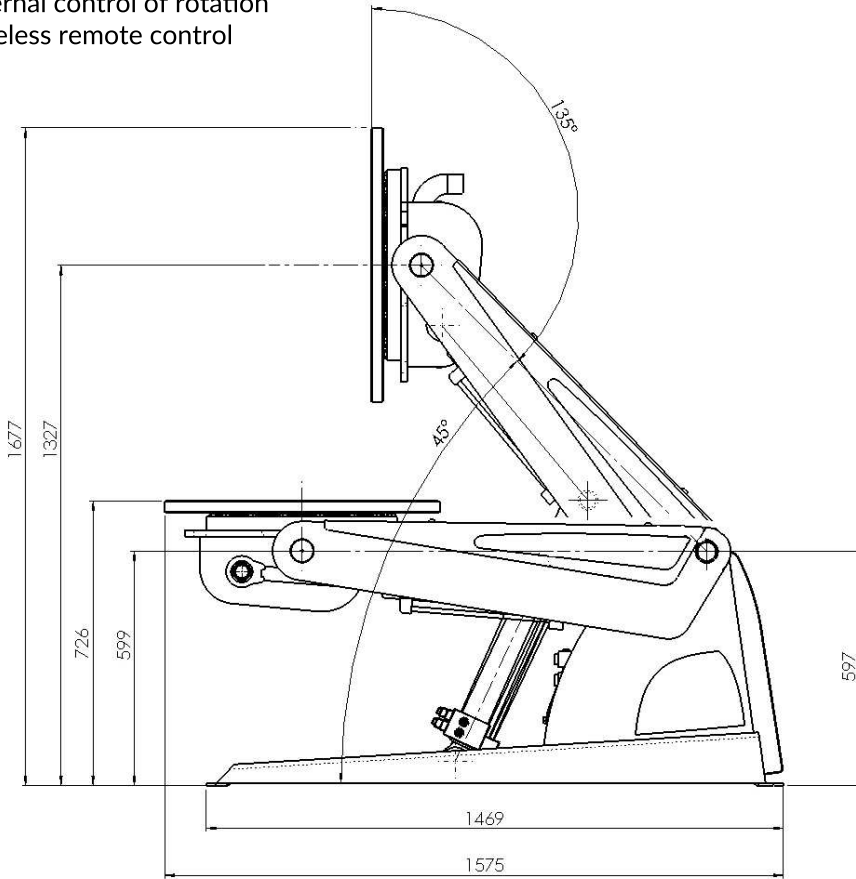

LOAD CAPACITY DIAGRAMS

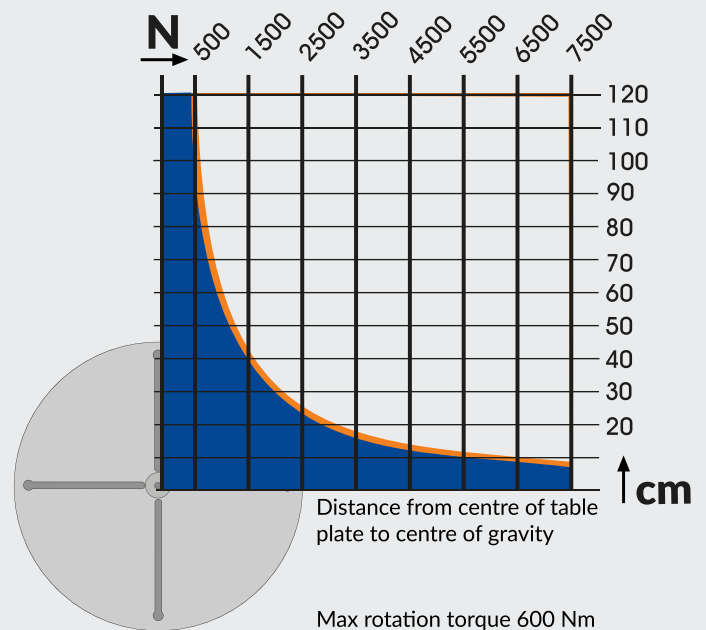
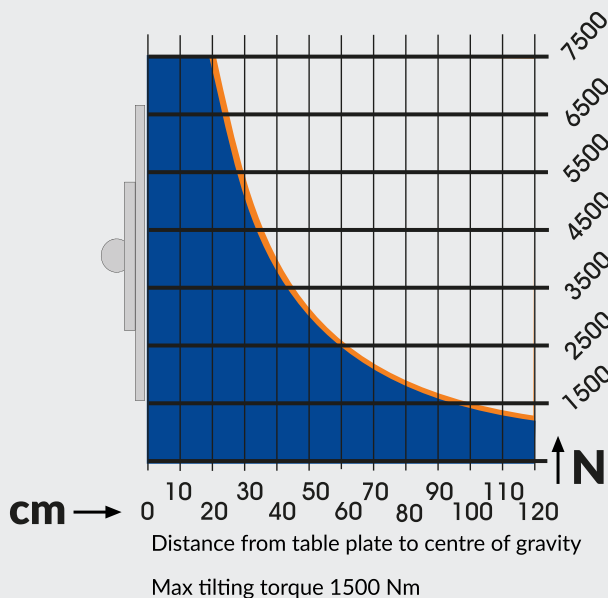

PEMAMEK LTD

Lamminkatu 47, FI-32200 Loimaa, Finland  
 Tel: +358 10 501 61

Email: info@pemamek.com www.pemamek.com